

OZONE SWITCH

Model OS-4

OS-4 Features

The OS-4 is a small form-factor ozone controller and monitor. It pairs with a sensor module featuring a calibrated user-replaceable sensor that enables users to efficiently operate and maintain an accurate ozone control system. Its digital display and LED indicators are easy to read and interpret. Additionally, an RS-232 serial output can connect to a computer, facilitating data logging and real-time data analysis.

- Front panel digital LCD displays ozone level.
- LED indicators illuminate when ozone exceeds the 0.1 ppm OSHA limit and when the connected ozone generator is activated.
- Interfaces with calibrated user-replaceable sensor modules.
- Two user-adjustable set points define the low and high limits for the ozone generator control relay.
- Analog outputs (4-20 mA and 0-2 VDC) are compatible with data loggers, PLCs, and other process controllers.
- Digital serial output (RS-232) allows for convenient connection to a computer or data logger. Data output: ozone (ppb), temperature (°C), and relative humidity (%).



OS-4 Indicator Lights and Display

PPM Ozone: Digital display in ppm (parts per million).

Above 0.1 ppm: Illuminates when the measured ozone exceeds 0.1 ppm (OSHA 8hr time-weighted average safety limit). A relay (TB2) engages with this indicator to provide remote alarm capability.

Power: Illuminates and blinks at a 1-second interval when powered on and receiving data from the sensor.

Generator Control: Illuminates when the ozone generator relay (TB1) is engaged, indicating the ozone generator is on.

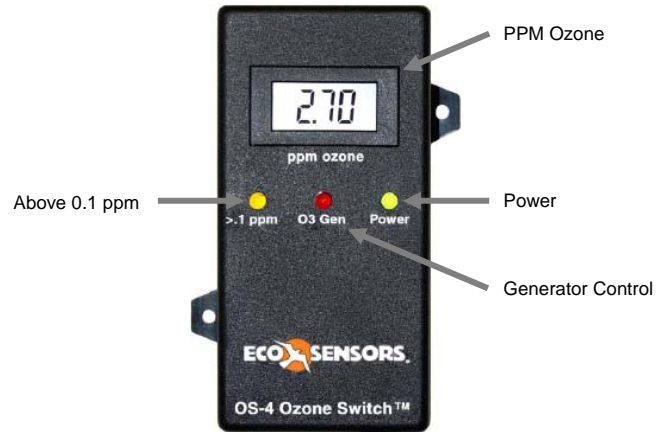

External Connections

The wiring terminals for the sensor module connections, OS-4 power, analog outputs, and relay outputs, are located behind the rear panel. For access, disconnect the OS-4 from power and remove the four screws and rear panel. The connection board will resemble this diagram.

TB1: OZONE GENERATOR CONTROL: Relay contacts with user adjustable control limits for operating an ozone generator. Refer to “Set Point Settings” for details.

TB2: 0.1 PPM HUMAN SAFETY LIMIT: Relay contacts tied to OSHA human safety limit (for remote indicator/alarm).

TB3: ANALOG OUTPUT: 4-20 mA and 0-2 VDC to external control equipment. The full scale analog output range is 0-20 ppm. NOTE: the 4-20 mA output is a current driver rather than a current-sink.

TB4: 12-24 VDC POWER: Power input for the OS-4

TB5: RS-232 OUTPUT: Serial data output. Refer to “Data Connection” for details.

TB6: SENSOR CABLE: Connect RED, BLK, and WHT to SM-module, TB-1 RED (+5V), BLK (GND), and WHT (DATA), respectively. Refer to Appendix A for an illustration and more details.

Power Connection

Disconnect power before opening the case to access the OS-4. Use only one of the following two methods to power the OS-4:

1. AC Adapter (included): 12-24 VDC, 300 mA (minimum), barrel connector. Refer to Tech Note P-101 at www.ecosensors.com/support for additional AC adapter specifications.
2. TB4: 12-24 VDC, 300 mA (minimum), wired connection (16-26 gauge)

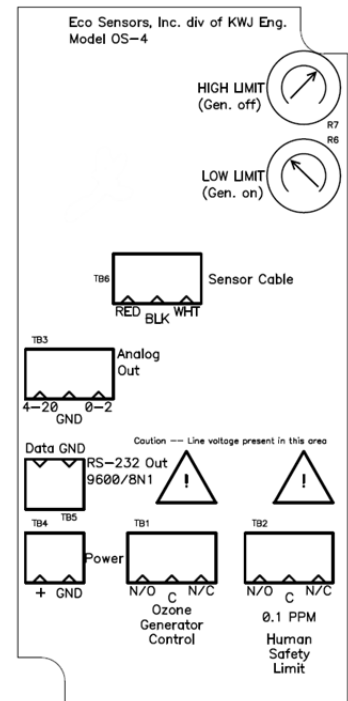

Initial Operation & Warm-Up

All standard connections between the OS-4 and the SM-module are made at the factory. Once power is connected to the OS-4 using one of the methods described above, the green power LED will illuminate and then blink at a 1-second interval as data is received from the SM-module. The LCD will display digits.

Power the OS-4 and connected SM-module for 1-hour before response testing. Prior to on-site process integration, operate on power for 24 hours. We recommend testing the instrument for positive response with an ozone generator when the instrument is received and again at the site where the instrument is installed.

Set Point Settings

Two dials are mounted on the circuit board, behind the rear panel. For access, disconnect the OS-4 from power and remove the four screws and rear panel. The dials are located in the upper, right corner. The dials are marked from 0-100, which represents percent of the 20 ppm full-scale range.

HIGH LIMIT: Maximum ozone set point at which the generator is turned off.

LOW LIMIT: Minimum ozone set point at which the generator is turned on.

Control Algorithm:

1. When the measured ozone concentration is less than LOW LIMIT, the RED O3 Gen LED will illuminate and relay TB1 (N/C) will engage, turning on the connected ozone generator.
2. When the ozone concentration exceeds HIGH LIMIT, the RED O3 Gen LED will turn off and relay TB1 (N/C) will disengage, turning off the ozone generator.
3. TB1, (N/C) will remain disengaged until the measured ozone concentration decreases below LOW LIMIT. The algorithm repeats from here.

Notes:

- The LOW LIMIT must be greater than zero (otherwise, the generator will never turn on).
- The HIGH LIMIT must always be greater than the LOW LIMIT.
- For most applications, it is recommended that a power relay is wired between the OS-4 and the ozone generator. The specifications of the power relay must match the load requirements of the ozone generator.

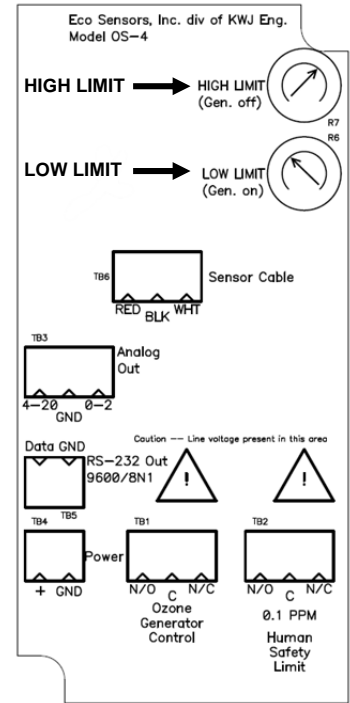

Data Connection

Data from the OS-4 and connected SM-module can be received by a computer via an RS-232 serial cable. Basic communication parameters are listed in the table to the right. For more details please consult the **RS-232 Communication Manual**, available at www.ecosensors.com/support.

Serial data is updated from the SM-module approximately once per second. An example serial data output stream is given below for 1 ppm (1000 ppb) ozone, 23 °C, and 33% relative humidity:

1000, 23, 33

Serial Communication Parameters

Parameter	Value
Speed (baud)	9600
Data bits	8
Stop bits	1
Parity	None
Flow Control	None

Specifications

Enclosure:	Wall mounted, self-extinguishing, black ABS plastic.
Size:	H = 5.05" (128.3 mm), W = 2.525" (64.14 mm), D = 1.625" (41.275 mm).
Wiring:	16-26 gauge
Power in:	12-24 VDC.
Power out:	+5 VDC to sensor.
Data in:	RS-232 serial data from remote sensor module (SM-module).
Data out:	RS-232, 9600 baud, 8N1 format.
Analog out:	0-2 V and 4-20 mA.
Control out:	Relays: 12A @ 30 VDC (resistive load), 12 A @ 250 VAC (resistive load).
Relay functions:	Ozone generator control, >100 ppb safety limit.
User controls (internal):	HIGH LIMIT set point, LOW LIMIT set point.
Numeric display:	4-digit, 0.4" (10 mm).
LED indicators:	Power/Sensor Data, above 100 ppb, ozone generator control.

Notes and Precautions

- Disconnect power before opening the case
- After connecting power, allow 1 hour for warm-up before testing. Allow 24 hours for warm-up before continued use.
- Keep the instrument dry.
- Do not drop the instrument or subject it to continuous vibration.
- Do not store or use the instrument in areas with high levels of dust.
- Do not clean the instrument with cleaning chemicals or solvents. If necessary, wipe clean with a damp cloth.
- Do not operate the instrument in environments with combustible gases and materials.
- Call a qualified electrician if you have any questions regarding electrical wiring codes.

Service and Maintenance

- **Tampering with the unit or attempting repairs will void the warranty.** Repairs should only be performed by Eco Sensors or an Eco Sensors authorized service representative.
- Instruments with problems during the warranty period should be returned as a system to the factory or authorized service representative for diagnosis and repair.
- We recommend checking the calibration monthly and changing the user replaceable sensor annually. It is generally more cost effective to replace sensors than to recalibrate them.
- Always remove power from the OS-4 and SM-module before opening the case. Follow the Wiring Diagram in Appendix A.

Warranty

This product is warranted against defects in materials and workmanship for one year following the date of purchase by the original owner. This warranty does not include damage to the product that results from misuse, accident, dropping, modifications or alterations, and it does not apply if the instructions in this manual are not followed, or if the unit is otherwise used outside its intended specifications.

If a defect develops during the warranty period, Eco Sensors, in its sole discretion, will repair the instrument or replace it with a new or reconditioned model of equivalent quality. In the event of replacement with a new or reconditioned instrument, the replacement unit will continue the warranty of the original unit.

If the product should become defective during the warranty period, please return it through your distributor, or call Eco Sensors at (800) 472-6626 or e-mail at sales@ecosensors.com to receive return instructions and a Return Materials Authorization (RMA) number.

Except as provided herein, Eco Sensors makes no warranties, express or implied, including warranties of merchantability and fitness for a particular purpose. Eco Sensors shall not be liable for loss of use of this instrument or other incidental or consequential damages, expenses or economic loss, or claims for such damage or economic loss.

RECORD YOUR SERIAL NUMBER HERE

KEEP THIS MANUAL AND WARRANTY FOR YOUR RECORDS.

Eco Sensors is a registered trademark of Eco Sensors, Division of KWJ Engineering, Inc.

© Eco Sensors, Division of KWJ Engineering, Inc. 2013.

For brochures, application and tech notes, and other useful information, visit our extensive website at www.ecosensors.com. E-mail us at sales@ecosensors.com.

Appendix A

SM-Module Wiring Illustration

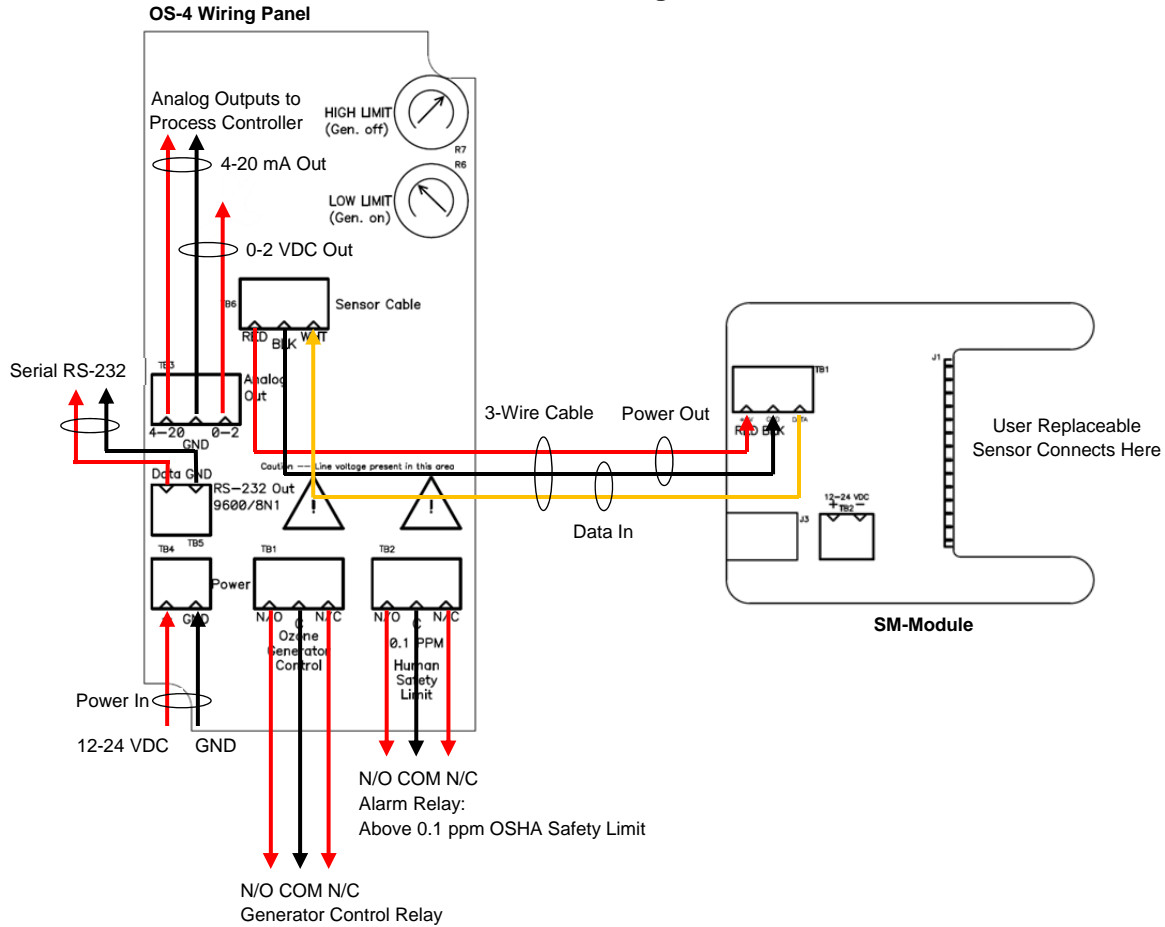

Appendix B

OS-4 Application Diagram

(for reference only)

